



**WINTERTHUR**  
TECHNOLOGY GROUP

# MOUNTED POINTS



# Technical information

**T52 ZY - 16 x 20 / 6 x 40**

Grinding wheel with spindle
Shape of mounted points
Cylindrical shape (ZY or W)
Conical shape (KE)
Spherical shape (KU)
Ogival shape (SP)
Taper cup shape (TO)
Cylindrical shape with conical end with truncated end (WK) or full point (ZE)
Cylinder shape with round end (WR)
Shape (A or B)
Outside diameter (D)
From 2 mm up to 80 mm (depends on the thickness T of the wheel)

Length of spindle	
Standard:	
ø 3 mm	30 mm
ø 6 mm	<b>40 mm</b>
ø 8 mm	40 mm
length tolerance +/- 3 mm	
Special length on request	

Spindle diameter		
3 mm	<b>6 mm</b>	8 mm,
9 mm	10 mm	
2,35 mm		
1/8 "	1/4 "	
Thread spindle and special dimensions on request		

Thickness (T)
from 2 mm up to 80 mm

**7A 70 P5 V15**

Abrasives	
Regular aluminium oxide	A, 1A
Semi friable aluminium oxide	3A, 5A
Pink aluminium oxide	<b>7A</b>
White aluminium oxide	8A
Red aluminium oxide	9A
Black silicon carbide	C, 1C
Green silicon carbide	2C

Grit size				
The grit size is characterized with numbers from coarse to very fine.				
Coarse	14	16	20	24
Medium	30	36	46	54 60
Fine	<b>70</b>	80	90	100 120
Very fine	150	180	220	240

Hardness grade	
The term hardness designates the resistance of the bond to grains being removed during the grinding process. The hardness is characterized in alphabetic order from very soft to very hard.	
Very soft	E F G
Soft	H I J K
Medium	L M N O
Hard	P Q R S
Very hard	T U V W

Works internal symbol
-----------------------

Type of bond	
The type of bonding material and its percentage of the total volume of the grinding wheel determine the strength, hardness and cutting performance of the wheel. The types of bonding are characterized according to EN 12413.	
Vitrified bond (V)	
Resinoid bond (B)	

Structure	
The structure is expressed in numbers ranging from 2 to 14. The higher the structure number, the more porous the grinding wheel.	
Dense	2 - 3
Medium	4 - 5
Open	6 - 7
Very open	8 - 9
Porous	10 - 11
Highly porous	12 - 14

## Shapes according to EN 12413

ZY Cylindrical shape

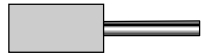

The grain size depends on the shape and diameter of the mounted point and the application.

KE Conical shape

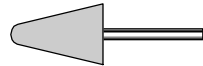

KU Spherical shape

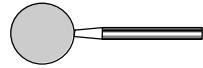

SP Ogival shape

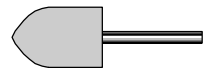

TO Taper cup shape

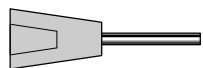

WK Cylindrical shape with conical end (truncated end)

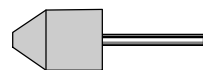

ZE Cylindrical shape with conical end (full point)

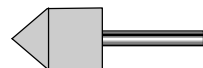

WR Cylinder shape with round end



Outside diameter (D) [mm]	Grit size	
	Roughing	Finishing
up to 2	120	220
3 - 7	70	90
8 - 13	46	70
14 - 29	36	70
larger than 29	24	46

W Cylindrical shape see following table

A Shape see page 4

B Shape see page 5

\_ Special shapes on request









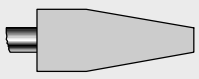
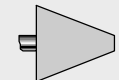

## Cylindrical mounted points shape W

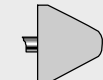
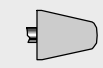
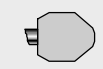
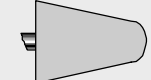

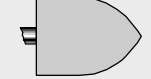

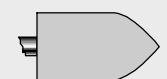

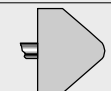
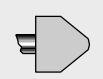

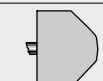
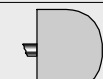
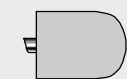









Designation	Dimensions [mm]		
	D	x T	/ S
W144	3	6	3
W145		10	
W146		13	
W149	4	6	3
W152	5	6	
W153		10	
W158	6	3	3
W160		6	
W162		10	
W163	6	13	3
W164		20	
W174		10	
W175	10		
W176	13		
W177	10	20	6
W178		25	
W179		32	
W182	13	3	6

Designation	Dimensions [mm]		
	D	x T	/ S
W183	13	6	6
W184		10	
W185		13	
W186	13	20	6
W187		25	
W188		40	
W189	16	50	6
W194		13	
W195		20	
W196	16	25	6
W197		50	
W200		20	
W201	6		
W202	10		
W203	20	13	6
W204		20	
W205		25	
W207	40	40	6











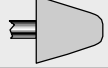
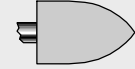



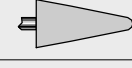
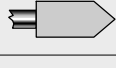





Designation	Dimensions [mm]		
	D	x T	/ S
W208	20	50	6
W215		3	
W216		6	
W217	25	10	6
W218		13	
W220		25	
W221	25	40	6
W222		50	
W225		6	
W226	30	10	6
W228		20	
W230		30	
W232	40	50	6
W235		6	
W236		13	
W237	40	25	6
W238		40	
W242		50	







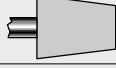

















# Shapes Type A

Designation	Shape	D x T [mm]
A1		22x63
A2		25x32
A3 S		16x45
A3		25x70
A4		32x32
A5		20x28
A6		20x28
A7		30x50
A8		20x50
A9		30x50
A10		22x70
A11		22x50
A12		18x32
A13		28x28
A14		18x22
A15		7x25
A16		40x40
A18		40x40
A19		30x50

Designation	Shape	D x T [mm]
A20		40x50
A21		25x25
A22		20x16
A23		20x25
A24		7x20
A25		Ø 25
A26		Ø 16
A27		Ø 30
A28		Ø 40
A31		35x25
A32		25x25
A33		25x13
A34		38x10
A35		25x10
A36		40x10
A37		32x6
A38		25x25
A39		20x20

## Shapes Type B

Designation	Shape	D x T [mm]
B41		16x16
B42		13x19
B43		6,5x8
B44		5,5x9,5
B51		11x19
B52		9,5x19
B53		8x16
B54		6,5x13
B55		3,5x6,5
B61		19x11
B62		13x9,5
B63		6,5x5
B64		6,5x3
B65		3,5x3,5
B71		16x5,5
B72		13x4
B73		13x4
B81		19x8
B82		13x6,5
B83		9,5x5
B84		8x5
B91		13x16
B92		6,5x6,5
B93		5x5

Designation	Shape	D x T [mm]
B94		4,5x3
B96		3,5x6,5
B97		3,5x9,5
B98		3x6,5
B101		16x18
B102		16x13
B103		16x5
B104		8x9,5
B105		6,5x6,5
B111		11,5x17,5
B112		9,5x13
B113		6,5x6,5
B114		5,5x9,5
B115		2,5x3,5
B121		Ø 13
B122		Ø 9,5
B123		Ø 5
B124		Ø 3,5
B131		13x13
B132		9,5x13
B133		9,5x9,5
B134		8x9,5
B135		6,5x13
B136		6,5x8

# Specifications

Application	Resinoid bond		Vitrified bond	
	Edge grinding	Surface grinding	Edge grinding	Surface grinding
Steel: unalloyed steel, construction steel, tool steel, high speed steel	5A36 R5 B25	5A24 P5 B25	7A46 Q5 V 7A70 P5 V	7A46 N5 V 7A70 M5 V 54A46 P5 V604
Alloy steel: stainless and acid resistant steel, high alloyed steel	8A36 P5 B13 1A36 Q6 B25	8A36 N5 B13 1A36 P5 B25	8A70 P5 V15	8A46 M6 V15
Cast materials: cast steel, high alloyed cast steel, grey cast iron, nodular cast iron	1A24 R6 B25	1A24 Q6 B25	350-7A24 Q4 V15	350-7A24 P5 V15
Non-ferrous materials: aluminium, copper, brass, bronze	5A46 P6 B107	5A46 N6 B107	1C36 Q4 V81	1C24 P4 V81
Titanium, titanium alloy Ni-Co-alloy	1A46 N6 B25S		29A46-2 M6 V601	
Tungsten carbide and ceramics			2C60 M6 V75	2C60 K7 V75
Rubber, plastics			8AH1-2 K-V490S 2C30 M6 V75	8AH2-3 J-V490S 2C24 L6 V75

Edge grinding: - Hard quality  
 - High edge-resistance  
 - High lifetime  
 - Low tool wear

Surface grinding: - Soft quality  
 - High material removal rate  
 - Short grinding time

## Selection of mounted points

The arrangement of RAPPOLD-WINTERTHUR mounted points contains the most important shapes and dimensions used for universal operations in workshops.

The selection consists of 18 mounted points in different shapes ZY, KE, SP, TO, KU with spindle diameter 6 mm.

These mounted points are obtainable in the specification 7A70 P5 V and 7A46 Q5 V.

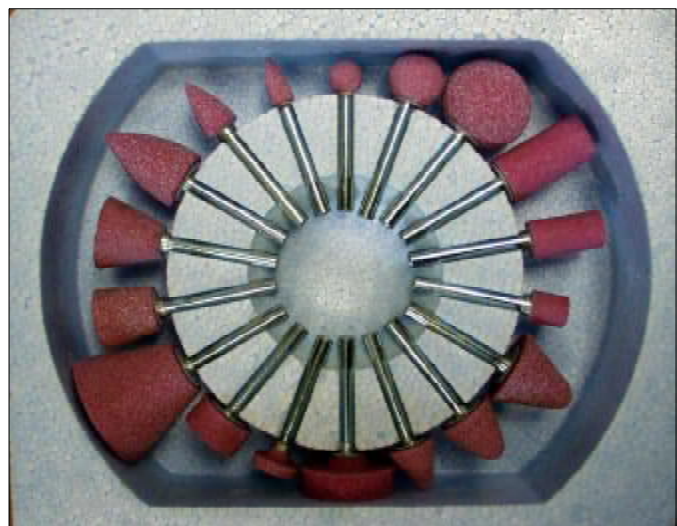

# Safety information

RAPPOLD-WINTERTHUR mounted points are admissible for a peripheral speed of max. 50 m/s for offhand and manually guided grinding according to EN 12413.

- Weight and shape of the grinding wheel
- Concentricity
- Spindle dimension
- Overhang length
- Shaft specification

mounted points, which means that they correspond to the safety requirements according to EN 12413 for bonded abrasives.



The maximum permissible operating speed depending on the spindle dimension and overhang lengths is determined in EN 12413, and must be considered to avoid the shaft's turn off.

The maximum peripheral speed is limited by the following criteria:

All above mentioned points are considered during the production of RAPPOLD-WINTERTHUR

## Labels for mounted points

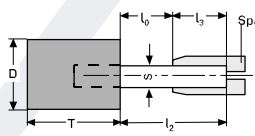
Front side

		
Order-No. 123456/07	Type T52ZY	
Dimension 16x32/6x40		
Specification 7A70 P5 V		
Sicherheitshinweis: B. w./p.t.o./T.S.V.P.		
Zulässige Drehzahl (max. RPM) bei einer offenen Schaftlänge $l_0$ von:		
10 mm	15 mm	20 mm
51000 1/min.	43400 1/min.	37200 1/min.
		
		
G 2 - Etikett aufbewahren! Bei Nachbest. beifügen!		

Back

### Safety information

The mounted point which is described on the front side can be used for a max. peripheral speed of 50 m/s. The safety and use of mounted points is limited by the following factors:

- if the minimum clamping length of the spindle  $l_3$  of 10 mm is not adhered to,
- if the stipulated maximum speed is exceeded in conformity with the overhang length  $l_0$ .

EN 12413 and DIN 69170, part 3 and 4 for mounted points have to be kept.

Grinding part

- D Outside diameter [mm]
- T Thickness [mm]

Spindle

- S Diameter [mm]
- $l_0$  Overhang length [mm]
- $l_3$  Clamping length [mm]
- $l_2 = (l_0 + l_3)$  Length of the spindle [mm]  
Tolerance for  $l_2$  +/- 3 mm

The labels for RAPPOLD-WINTERTHUR mounted points are marked with the max. permissible operating speed of the corresponding mounted point for a length of the spindle of  $l_0$  10, 15, and 20 mm.

## Safety recommendations

The safety instructions on the labels especially the max. permissible operating speed (r.p.m.) must be taken into consideration when using RAPPOLD-WINTERTHUR mounted points.



Wear safety goggles



Use hearing protection

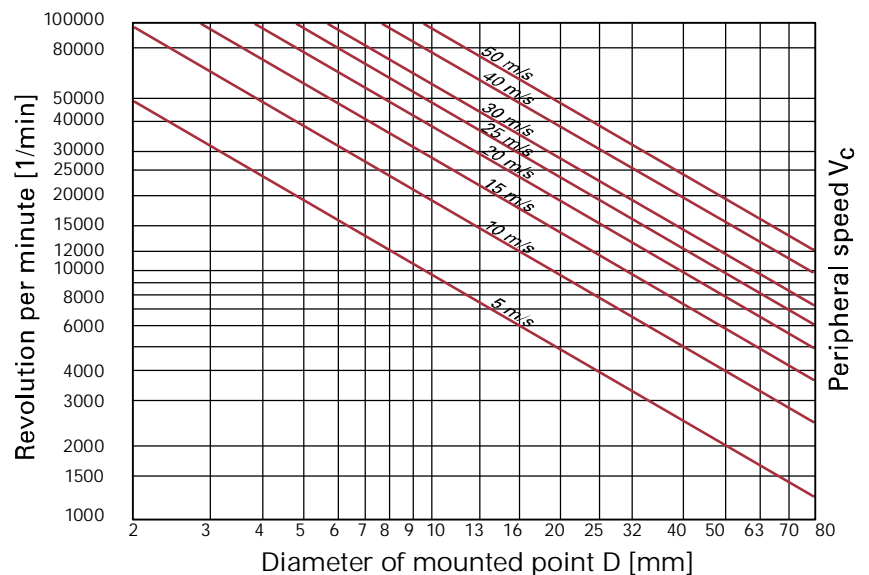



**WINTERTHUR**  
TECHNOLOGY GROUP

## Switzerland

Winterthur Schleiftechnik AG  
Oberer Deutweg 4  
P.O.B. 56  
CH-8411 Winterthur  
Telephone +41 (0)52 234 41 41  
Facsimile +41 (0)52 232 51 01  
E-Mail [wst@rappold-winterthur.com](mailto:wst@rappold-winterthur.com)

## Austria

Rappold Winterthur  
Technologie GmbH  
St.-Magdalener Straße 85  
P.O.B. 52  
A-9500 Villach  
Telephone +43 (0)4242 41 811-0  
Facsimile Inland +43 (0)4242 41 811-700  
Facsimile Export +43 (0)4242 41 811-701  
E-Mail [office@rappold-winterthur.at](mailto:office@rappold-winterthur.at)

## Sweden

SlipNaxos AB  
SE-593 83 Västervik  
Telephone +46 (0)490 843 00  
Facsimile +46 (0)490 146 00  
E-Mail [support@slipnaxos.se](mailto:support@slipnaxos.se)

## Germany

Winterthur Schleiftechnik GmbH  
Hundsschleestraße 10  
D-72766 Reutlingen  
Telephone +49 (0)7121 93 24-0  
Facsimile +49 (0)7121 93 24-24  
E-Mail [info@rappold-winterthur.de](mailto:info@rappold-winterthur.de)

## England

SlipNaxos Winterthur (GB) Ltd.  
2 Oakham Drive  
GB-Sheffield, S3 9QX  
Telephone +44 (0)114 275 42 11  
Facsimile +44 (0)114 275 41 32  
E-Mail [kaye.walker@slipnaxos-winterthur.co.uk](mailto:kaye.walker@slipnaxos-winterthur.co.uk)

## Denmark

SlipNaxos Winterthur A/S  
Brudelysvej 4  
DK-2880 Bagsvaerd  
Telephone +45 44 68 25 55  
Facsimile +45 44 65 79 55  
E-Mail [abrasifs@slipnaxos.fr](mailto:abrasifs@slipnaxos.fr)

## Finland

Rapoflex Oy  
Vitikka 1D  
PL 122  
SF-02631 ESPOO  
Telephone +358 (0)9 549 98 700  
Facsimile +358 (0)9 549 98 710  
E-Mail [rapoflex@rapoflex.fi](mailto:rapoflex@rapoflex.fi)

## Norway

SlipNaxos AB  
Solheimsgt. 1  
N-2000 Lillestrom  
Telephone +47 64 84 35 70  
Telefax +47 64 84 35 75  
E-Mail [tone.borgen@slipnaxos.no](mailto:tone.borgen@slipnaxos.no)

## France

SlipNaxos Rappold France  
70, Rue des chantiers du beaujolais - Limas  
F-69659 Villefranche Cedex  
Telephone +33 (0)4 74 02 94 40  
Telefax +33 (0)4 74 02 94 41  
E-Mail [abrasifs@slipnaxos.fr](mailto:abrasifs@slipnaxos.fr)

## France

Winterthur Technologie (France) Sarl  
31, Rue des Jardins  
F-68000 Colmar  
Telephone +33 (0)389 24 01 31  
Facsimile +33 (0)389 24 07 26  
E-Mail [france@winterthur-tech.fr](mailto:france@winterthur-tech.fr)

## Russia

OOO Rappold Winterthur  
ul. Leskova, 30  
127560 Moskau  
Telephone +7 495 78 19 600  
Facsimile +7 495 78 19 601  
E-Mail [info@rappold-winterthur.ru](mailto:info@rappold-winterthur.ru)

## Poland

Rappold Winterthur  
Technika Szlifierska  
Ul. Borowa 1  
PL-41-250 Czeladz  
Telephone +48 32 763 45 00  
Facsimile +48 32 763 45 01  
E-Mail [info@rappold-winterthur.pl](mailto:info@rappold-winterthur.pl)

## Slovenia

Rappold Winterthur  
brusilna tehnika d.o.o.  
Ulica Mirka Vadnova 19  
SI-4000 Kranj  
Telephone +386 (0)4 23 40 679  
Facsimile +386 (0)4 23 40 678  
E-Mail [office@rappold-winterthur.si](mailto:office@rappold-winterthur.si)

## Czech republic

Rappold Brno s.r.o.  
Mařikova 1  
CZ-621 00 Brno  
Telephone +420 (0)5 41 229 071  
Facsimile +420 (0)5 41 229 070  
E-Mail [info@rappold-winterthur.cz](mailto:info@rappold-winterthur.cz)

## USA

Winterthur Corporation  
10 Viking Road  
Webster, MA 01570  
Telephone +1 508 949 10 61  
Facsimile +1 508 949 20 86  
E-Mail [winterthurusa-cs@att.net](mailto:winterthurusa-cs@att.net)